

Efficiency and Adaptability: Exploring Self-Aligning Ball Bearings

Introduction

Efficiency and adaptability are essential attributes in the design and operation of machinery and equipment. In this context, Self-Aligning Ball Bearings (SABBs) play a crucial role. These bearings are engineered to provide optimal performance in various applications by allowing for misalignment and compensating for shaft deflections. Let's delve deeper into the significance and functionality of Self-Aligning Ball Bearings.

Self-Aligning Ball Bearings (SABBs) are a type of rolling-element bearing designed to accommodate misalignment between the shaft and the housing. Unlike traditional ball bearings, which require precise alignment for smooth operation, SABBs are capable of aligning themselves to a certain degree, thereby reducing the risk of premature wear and failure due to misalignment.

The unique design of SABBs includes two rows of balls, a common spherical raceway in the outer ring, and two deep raceways in the inner ring. This configuration allows the bearing to self-align under angular misalignment conditions, ensuring uniform load distribution and minimizing frictional losses.

Key Features of [Self-Aligning Ball Bearings](#):

Misalignment Compensation: SABBs can accommodate misalignment caused by shaft deflections, mounting errors, or thermal expansion of the shaft and housing components. This ability to self-align enhances the overall efficiency and performance of the machinery.

High Load-Carrying Capacity: Despite their self-aligning capability, SABBs maintain a high load-carrying capacity, making them suitable for applications with moderate to heavy radial and axial loads.

Reduced Maintenance Requirements: The self-aligning feature of SABBs helps reduce the need for frequent maintenance and adjustment, leading to lower operational costs and extended bearing life.

Adaptability to Harsh Conditions: SABBs are well-suited for use in environments with high levels of

contamination, vibration, or shock loads, thanks to their robust construction and ability to compensate for misalignment.

Applications of Self-Aligning Ball Bearings:

SABBs find widespread use in various industries and applications, including:

Automotive: Steering systems, transmissions, and wheel hubs.

Industrial Machinery: Conveyor systems, pumps, fans, and textile machinery.

Mining and Construction: Crushers, vibrating screens, and heavy-duty equipment.

Marine and Offshore: Ship propulsion systems, winches, and marine cranes.

In summary, Self-Aligning Ball Bearings (SABBs) offer an efficient and adaptable solution for machinery and equipment design, allowing for misalignment compensation and optimal performance in diverse operating conditions. In the following sections, we will explore the operating principles, installation best practices, and maintenance guidelines for SABBs to further understand their role in enhancing efficiency and adaptability in industrial applications.



Self-Aligning Ball Bearings

Understanding Self-Aligning Ball Bearings

Self-Aligning Ball Bearings (SABBs) are a vital component in many industrial applications due to their unique design and functionality. We will delve into the intricacies of SABBs, including their design, components, and operating principles.

<p>Design and Components</p>	<p>SABBs consist of two rings—an inner ring and an outer ring—each with a concave raceway. The inner ring is typically mounted on a shaft, while the outer ring is housed in a bearing housing. Between the rings are the balls, which are responsible for carrying the load and facilitating rotation. Additionally, SABBs may feature cages to separate the balls and maintain proper spacing.</p>
<p>Comparison with Other Bearings</p>	<p>One of the distinguishing features of SABBs is their ability to accommodate misalignment. Unlike traditional bearings, which require precise alignment for optimal performance, SABBs can tolerate angular misalignment between the shaft and the housing. This capability makes them particularly suitable for applications where shaft deflections or mounting errors are common.</p>
<p>Operating Principles</p>	<p>The operating principles behind self-alignment in SABBs are based on the geometry of their raceways. The concave shape of the raceways allows the balls to move freely within the bearing, adjusting their positions to compensate for misalignment. As a result, the load is distributed evenly across the bearing surfaces, reducing friction and wear.</p>

Significance in Reducing Friction and Wear

The ability of SABBs to self-align plays a crucial role in minimizing friction and wear in machinery and equipment. By allowing for misalignment, SABBs prevent localized stress concentrations, which can lead to premature failure. This not only extends the lifespan of the bearings but also enhances the overall efficiency and reliability of the system.

In summary, Self-Aligning Ball Bearings (SABBs) are engineered to provide efficient and reliable performance in applications where misalignment is a concern. Their unique design and operating principles enable them to accommodate angular misalignment, reducing friction and wear and contributing to the efficiency and adaptability of industrial systems.

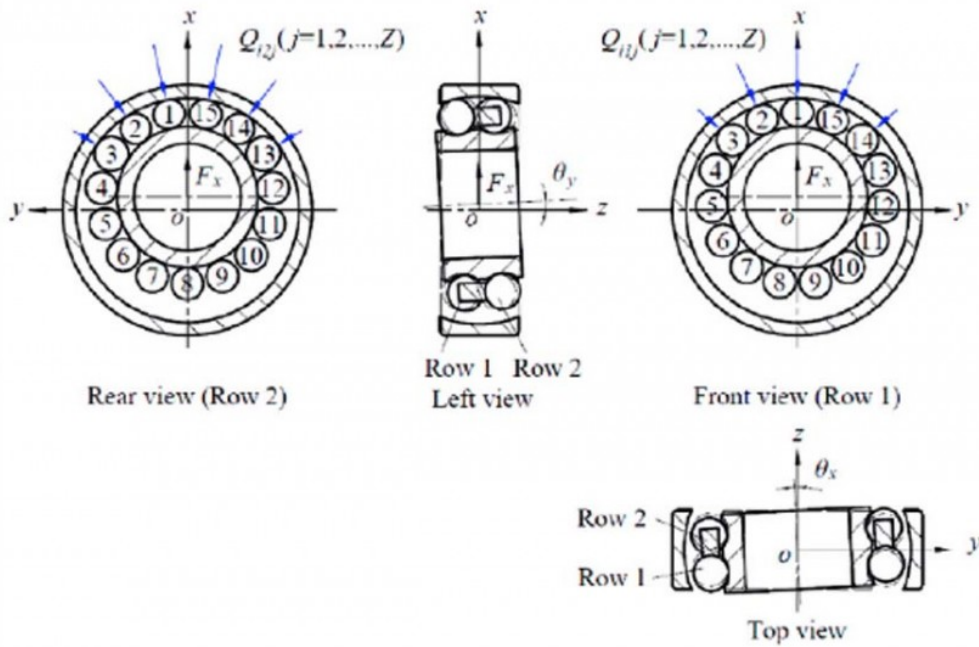

Self-Aligning Ball Bearings

Construction and Mechanisms of Self-Aligning Ball Bearings

Self-Aligning Ball Bearings (SABBs) are engineered with a unique construction that enables them to accommodate misalignment and maintain optimal performance in various industrial applications. We will explore the construction and mechanisms of SABBs, shedding light on their double-row design, outer ring raceway, and cage structure.

Double-Row Construction:

One of the distinguishing features of SABBs is their double-row design, consisting of two rows of balls separated by a common spherical raceway in the outer ring. This construction allows SABBs to accommodate misalignment in both axial and angular directions, providing greater flexibility in mounting and operation. By distributing the load over multiple rows of balls, SABBs can withstand higher radial and axial loads while maintaining smooth rotation.

Spherical Outer Ring Raceway:

The spherical outer ring raceway of SABBs is integral to their ability to compensate for shaft deflections and mounting errors. This curved raceway allows the balls to self-align within the bearing, adjusting their positions to maintain contact with the raceways under varying operating conditions. As a result, SABBs can effectively absorb shocks and vibrations, reducing the risk of premature wear and failure.

Importance of Cage Design:

Cages play a critical role in SABBs by separating the balls and guiding them along the raceways during rotation. The design and material of the cage are essential considerations in ensuring smooth operation and load distribution within the bearing. Common cage materials include steel, brass, and synthetic polymers, each offering unique advantages in terms of strength, durability, and lubrication retention.

Mechanisms for Smooth Rotation:

The combination of the double-row construction, spherical outer ring raceway, and optimized cage design enables SABBs to achieve smooth rotation and uniform load distribution. Even under misaligned conditions, the balls can freely roll along the raceways, minimizing friction and wear. This ensures efficient power transmission and extends the lifespan of the bearing and surrounding components.

In summary, the construction and mechanisms of Self-Aligning Ball Bearings (SABBs) are designed to enhance their misalignment capability and ensure reliable performance in diverse operating conditions. By incorporating a double-row design, spherical outer ring raceway, and carefully engineered cages, SABBs offer efficiency and adaptability in industrial applications, contributing to overall equipment reliability and productivity.

Brand	SKF	FAG	NSK
Origin	Sweden	Germany	Japan

Founded	1907	1883	1916
Key Features	High-quality steel construction Advanced sealing solutions Wide range of sizes and designs	Precision engineering Innovative cage designs Extensive product range	Innovative bearing technologies High-speed capabilities Diverse product portfolio
Applications	Industrial machinery Automotive Aerospace	Heavy machinery Automotive Power generation	Automotive Industrial machinery Aerospace
Advantages	Excellent performance in harsh environments Long service life Global distribution network	Superior load-carrying capacity Optimal lubrication solutions Enhanced reliability	High-speed capability Precision engineering Exceptional durability
Market Presence	Widely recognized brand Global market leader Extensive aftermarket support	Renowned for quality and reliability Trusted by industry professionals Strong presence in Europe and Asia	Globally recognized brand Strong presence in Asia, Europe, and Americas Extensive OEM partnerships

This table compares three prominent brands of Self-Aligning Ball Bearings: SKF, FAG, and NSK. Each brand offers unique features, advantages, and market presence, catering to various industrial and automotive applications.

Applications and Performance Characteristics

Self-Aligning Ball Bearings (SABBs) find widespread use across diverse industries and machinery due to their unique design and performance characteristics. We will explore the applications of SABBs in various industrial sectors and delve into their performance under different operating conditions.

Applications of Self-Aligning Ball Bearings:

SABBs are integral components in numerous applications where misalignment compensation and reliable performance are essential. Some of the key industries and machinery where SABBs are commonly used include:

Conveyor Systems: SABBs play a crucial role in conveyor systems, where they support heavy loads and provide flexibility in shaft alignment, ensuring smooth material handling operations.

Agricultural Machinery: In agricultural equipment such as tractors, combines, and harvesters, SABBs help withstand the rigors of field operations, absorbing shocks and vibrations while maintaining precise shaft alignment.

Industrial Gearboxes: SABBs are employed in industrial gearboxes to support the shafts and gears, allowing for misalignment due to thermal expansion or manufacturing tolerances, thereby enhancing the efficiency and

longevity of the gearbox.

Pumps and Compressors: In pumps and compressors used in various industries, SABBs provide reliable performance under fluctuating loads and speeds, contributing to energy efficiency and operational reliability.

Performance Characteristics of Self-Aligning Ball Bearings:

The performance of SABBs is influenced by several factors, including operating speed, temperature, and misalignment angles. Here are some key performance characteristics of SABBs:

Speed Capability: SABBs are capable of operating at high speeds while maintaining stability and minimizing frictional losses, making them suitable for applications requiring rapid rotation.

Temperature Resistance: SABBs exhibit excellent temperature resistance, allowing them to operate reliably in environments with elevated temperatures or fluctuations, such as industrial ovens or kilns.

Misalignment Tolerance: SABBs can accommodate angular misalignment between the shaft and housing, compensating for up to a certain degree of misalignment without compromising performance or bearing life.

Benefits of Self-Aligning Ball Bearings:

The utilization of SABBs offers several benefits in industrial applications, including:

Improved Equipment Reliability: By mitigating the effects of misalignment and reducing stress on components, SABBs enhance the overall reliability and uptime of machinery and equipment.

Reduced Maintenance Costs: SABBs require less frequent maintenance and adjustment compared to rigid bearings, resulting in lower operational costs and downtime.

Extended Service Life: The ability of SABBs to adapt to varying operating conditions and absorb shocks helps prolong the service life of equipment and minimize the need for premature replacements.

In summary, Self-Aligning Ball Bearings (SABBs) play a vital role in a wide range of industrial applications, offering efficient misalignment compensation and reliable performance under diverse operating conditions. Their versatility, coupled with their ability to improve equipment reliability and reduce maintenance costs, makes them indispensable components in modern machinery and mechanical systems.



Self-Aligning Ball Bearings

Installation and Maintenance Best Practices

Proper installation and maintenance are crucial for ensuring the optimal performance and longevity of Self-Aligning Ball Bearings (SABBs). We will discuss the best practices for installing and maintaining SABBs, focusing on key considerations and recommendations.

Installation Procedures:

When installing SABBs, it's essential to follow specific guidelines to ensure proper alignment and functionality:

Shaft and Housing Considerations: Before installation, thoroughly inspect the shaft and housing for any damage, burrs, or contamination. Ensure that the mounting surfaces are clean and free from debris to prevent premature bearing failure.

Preload Adjustment: Proper preload adjustment is vital for optimizing the performance of SABBs. Follow the manufacturer's recommendations for adjusting the preload to achieve the desired axial and radial clearance.

Alignment Techniques: Use precision alignment tools to align the shaft and housing accurately. Misalignment can lead to increased friction, premature wear, and reduced bearing life. Proper alignment ensures smooth operation and extends the service life of SABBs.

Maintenance Recommendations:

Regular maintenance is essential for monitoring the condition of SABBs and detecting early signs of wear or damage:

Implementing Maintenance Schedules: Establish regular maintenance schedules to inspect SABBs for signs of wear, corrosion, or damage. Schedule inspections at predetermined intervals based on the operating conditions and workload.

Monitoring Bearing Condition: During maintenance inspections, pay close attention to the condition of the SABBs. Check for unusual noise, vibration, or temperature fluctuations, which may indicate potential issues. Replace any bearings showing signs of wear or damage promptly to prevent equipment downtime and costly repairs.

Lubrication Practices:

Proper lubrication is critical for maximizing the performance and lifespan of SABBs:

Selecting Appropriate Lubricants: Choose lubricants specifically formulated for SABBs based on factors such as operating temperature, speed, and load. Consult with lubrication experts or refer to manufacturer recommendations to select the most suitable lubricant for your application.

Optimizing Lubrication Methods: Apply the lubricant evenly and adequately to ensure proper coverage of all bearing surfaces. Use automatic lubrication systems where applicable to maintain consistent lubrication levels and minimize the risk of over-lubrication or under-lubrication.

In conclusion, following proper installation and maintenance practices is essential for maximizing the efficiency and adaptability of Self-Aligning Ball Bearings (SABBs). By adhering to these guidelines, you can ensure smooth operation, reduce the risk of premature failure, and extend the service life of your bearings.

Advancements and Innovations in Self-Aligning Ball Bearings

Recent years have witnessed significant advancements in Self-Aligning Ball Bearings (SABBs) technology, leading to improved efficiency, adaptability, and reliability in various industrial applications. We will explore the latest innovations in SABBs, including materials, coatings, sealing solutions, and emerging trends shaping the future of bearing technology.

Improved Materials and Coatings	Manufacturers are continuously researching and developing new materials and coatings to enhance the performance and durability of SABBs:	
	Advanced Steel Alloys	Utilizing advanced steel alloys with superior strength and corrosion resistance improves the load-carrying capacity and lifespan of SABBs in harsh operating environments.
	Ceramic Balls	The use of ceramic balls in SABBs offers benefits such as reduced friction, higher operating speeds, and improved resistance to wear and fatigue, leading to longer bearing life and increased reliability.
	Specialized Coatings	Innovative coatings, such as diamond-like carbon (DLC) coatings and ceramic coatings, provide additional protection against wear, abrasion, and corrosion, prolonging the service life of SABBs and reducing maintenance requirements.
Sealing Solutions and Environmental Protection	Sealing solutions play a crucial role in preventing contamination and maintaining lubricant integrity in SABBs	

	Advanced Sealing Technologies	Incorporating advanced sealing technologies, such as labyrinth seals and contact seals, enhances the ingress protection of SABBs, preventing the intrusion of contaminants such as dust, water, and debris.
	Environmental Resistance	Specially designed seals and coatings provide enhanced resistance to extreme temperatures, chemicals, and abrasive particles, allowing SABBs to perform reliably in demanding applications, including heavy-duty industrial machinery and automotive systems.
Integration of Condition Monitoring and Predictive Maintenance	Emerging trends focus on integrating condition monitoring sensors and predictive maintenance algorithms into SABBs	
	Condition Monitoring Sensors	By integrating sensors into SABBs, manufacturers can collect real-time data on bearing temperature, vibration, and lubrication condition, enabling early detection of potential issues and proactive maintenance interventions.
	Predictive Maintenance Algorithms	Advanced analytics and machine learning algorithms analyze the sensor data to predict impending bearing failures and prescribe maintenance actions, minimizing downtime and optimizing equipment reliability.

Future Developments and Implications:

Looking ahead, future developments in SABBs technology are poised to further revolutionize bearing performance and functionality:

Enhanced Performance: Continued research into novel materials, coatings, and design configurations will lead to SABBs with even higher load capacities, lower friction coefficients, and extended service intervals, improving overall equipment efficiency and productivity.

Smart Bearing Systems: The integration of IoT connectivity and cloud-based monitoring platforms will enable smart bearing systems capable of self-diagnosis, remote troubleshooting, and performance optimization, ushering in a new era of predictive maintenance and industrial automation.

In summary, advancements and innovations in Self-Aligning Ball Bearings (SABBs) technology are driving significant improvements in efficiency, adaptability, and reliability across various industries. By leveraging these innovations, businesses can enhance equipment performance, reduce maintenance costs, and achieve operational excellence in an increasingly competitive marketplace.

Conclusion

In conclusion, our exploration into Self-Aligning Ball Bearings (SABBs) has shed light on their design, functionality, and diverse applications across various industries.

Recap of Key Insights:

we have delved into the unique design features of SABBs, including their ability to accommodate misalignment and compensate for shaft deflections. Unlike conventional bearings, SABBs offer a versatile solution that reduces the risk of premature wear and failure, thereby improving overall equipment performance and reliability.

Critical Role of SABBs:

The critical role of SABBs in modern machinery cannot be overstated. By effectively managing misalignment and reducing friction, SABBs contribute to smoother operation, lower maintenance requirements, and extended service life. From automotive steering systems to industrial conveyor belts, SABBs play a vital role in ensuring efficient and reliable performance across a wide range of applications.

Call to Action:

As we move forward, it is imperative for industry professionals to recognize the significance of SABB technology and leverage it to their advantage. By incorporating SABBs into machinery design and operation, businesses can optimize efficiency, adaptability, and reliability, ultimately gaining a competitive edge in the market.

In conclusion, Self-Aligning Ball Bearings (SABBs) represent a cornerstone of modern engineering, offering unparalleled efficiency and adaptability in managing misalignment and improving equipment performance. It is time for industry leaders to embrace SABB technology and unlock its full potential for innovation and growth.

FAQs: Common Questions About Self-Aligning Ball Bearings

What are Self-Aligning Ball Bearings (SABBs)?

Self-Aligning Ball Bearings (SABBs) are a type of rolling-element bearing designed to accommodate misalignment between the shaft and the housing. They consist of two rows of balls, a common spherical raceway in the outer ring, and two deep raceways in the inner ring.

How do SABBs accommodate misalignment?

SABBs can accommodate misalignment by allowing the inner ring to tilt relative to the outer ring. This capability helps compensate for shaft deflections, mounting errors, or thermal expansion of the shaft and housing components.

What are the key features of SABBs?

Misalignment Compensation: SABBs can compensate for misalignment, ensuring smooth operation and reducing the risk of premature wear.

High Load-Carrying Capacity: Despite their self-aligning capability, SABBs maintain a high load-carrying capacity, making them suitable for various applications.

Reduced Maintenance Requirements: The self-aligning feature of SABBs reduces the need for frequent maintenance and adjustment, leading to lower operational costs.

Where are SABBs commonly used?

SABBs find widespread use in industries such as automotive, industrial machinery, mining, and marine. They are utilized in applications such as conveyor systems, pumps, crushers, and ship propulsion systems.

How do I install and maintain SABBs?

Proper installation procedures, including shaft and housing considerations, preload adjustment, and alignment techniques, are essential for maximizing SABB performance. Regular maintenance schedules should be implemented to monitor SABB condition and detect early signs of wear or damage.

What lubricants should be used for SABBs?

Selecting appropriate lubricants and lubrication methods is crucial for optimizing SABB performance and lifespan. It is recommended to use high-quality lubricants suitable for the operating conditions and to follow manufacturer guidelines for lubrication intervals.

What are the advancements in SABB technology?

Recent advancements in SABB technology include improved materials, coatings, and sealing solutions, as well as the integration of condition monitoring sensors and predictive maintenance algorithms. These advancements aim to further enhance the efficiency, adaptability, and reliability of SABBs in various applications.

How do SABBs compare to other types of bearings?

Compared to other types of bearings, SABBs offer unique advantages in terms of misalignment compensation and adaptability. They are capable of aligning themselves to a certain degree, reducing friction and wear in machinery and mechanical systems.

In summary, Self-Aligning Ball Bearings (SABBs) are versatile components that offer efficient and adaptable solutions for managing misalignment in various industrial applications. Understanding their design, features, and maintenance requirements is essential for maximizing their performance and ensuring long-term reliability.